

PSC8 • PSC16 • PSC24

Multichannel Pressure Scanner Simultaneous acquisition of 4 or 5 pressure signals

- Measuring ranges selectable from 125 Pa to 15 kPa (0.25 to 150 mbar) uni- and bi-directional, higher range on request
- Non-linearity & hysteresis: max. $\pm 0.25\%$ FSS
- Data transfer via USB without external power supply
- CAN bus, LAN and RS232 versions available
- Sampling rate per channel up to max. 50Hz
- Software and driver for LabVIEW and DBC files are included



General Description

The PSC pressure scanners are capable of measuring multiple pressure signals simultaneously. Temperature-compensated transducers feature high accuracy and minimal offset drift. In all devices each pressure channel range can be customized individually according to customer specifications.

The PSC24 has 24 pressure channels. Reference pressure lines of all sensors are connected to a single pressure port in standard configuration. A special differential version with reference ports for each line is also available.

The data is transmitted as ASCII text in the unit Pascal [Pa]. The transmission rate can be set in the range between 1 and 50 Hz.

A tare function can be triggered either by pressing the TARE button or by a software command.

Power for PSC devices equipped with USB or CAN interface is supplied via USB or respectively via CAN-port. For the version with built-in magnetic valves and LAN interface an external power supply (9-24 V, 1 A) has to be connected with the device.

All PSC versions are equipped with an USB interface, allowing easy configuratio. When connected via USB the pressure scanner identifies itself to the host PC as virtual COM port. Thus, any software supporting serial protocols can be used for communication. The LAN-version sends the data using the TCP-IP protocol. A direct connection can be set up via Telnet (Port 10001).

A recording software and an example program in LabVIEW (source code) are shipped with the device. For devices with CAN bus interface a DBC-file is included in the shipment.

On request there are different customization options:

- selection of different sensor pressure ranges
- parallel connection of sensors with different ranges for application where high accuracy is required

Technical Specifications

Measurement Range			Max. Proof Pressure		Availability
kPa	mbar	Bereich	kPa	bar	
0,125	100	uni/bi	200	0,25	
0,25	2.5	uni/bi	25	0.25	
0,5	5.0	uni/bi	25	0.25	
1,25	12.5	uni/bi	50	0.50	
2,5	25	uni/bi	50	0.50	
5,0	50	uni/bi	50	0.75	
7,5	75	uni/bi	50	1.20	
15	150	uni/bi	50	1.20	
≥34	≥340				On request
Accuracy and scan rates					
Nonlinearity & Hysteresis		max. ±0.25% FSS			
Scan rate per channel		1-50 Hz (PSC8: 100Hz)			
Power supply					
via USB		USB-powered (no additional power supply required)			
PSC-LAN / PSC-CAN		7-24 V, 50 mA			
Environmental conditions					
Temperature		5° C...50° C			
Humidity		0...95%, non-condensing			
Operating medium		Air and non-corrosive gases			
Dimensions					
Housing (standard)		130 x 55 x 170 mm (B x H x T)			
Pressure connectors		hose nozzles D = 2,0 mm			
Recommended tubes		Soft-PE and silicone tubes 1.5 x 3.5 mm			
Software and drivers					
Virtual COM-Port-Driver					
Configuration software					
LabVIEW-example program as sourcecode					
Supported operation systems					
Windows XP, 7, 8, 10, Linux					
Options					
All PSC systems can be optionally equipped with CAN bus, LAN or RS232					

Serial Interface

The virtual COM port can be operated at any baud rate. We recommend 19200, 8 data bits, no parity, 1 stop bit. DTR (Data Terminal Ready) must be asserted.

Command	Function	Answer
CAL a x	Set scaling factor for sensor a to value x	#Scaler=... Offset=...
CAL? A	Read scaling factors for sensor a	#Scaler=... Offset=...
EE_LOAD	Load calibration data from EEPROM	#EEPROM:loaded
EE_SAVE	Save calibration data to EEPROM	#EEPROM:saved
*IDN?	Read device ID	#PSC24-LAN 2.4.0 #SN35000
RATE x	Define sample rate range x = 20 ...5000 [ms] standard: 1000 [ms] → 1 [Hz]	#Rate=x ms #Error: Rate-Range
RATE 0	Activate request and trigger mode actual values are read only after manual command "?" is sent	#Request-Mode active
?	Read actual value (request-mode only)	
*RST	Load default settings	#RESET
SCAN_A x SCAN_B x SCAN_C x	Defines a scanlist (channel selection) binary, each bit represents one channel	
TARA	Zero adjustment for all sensors	#TARA
FILTER x	Activate exponential filter 0 = deactivated; >0 = filter range in ms	#FILTER=x

Every command is terminated by a line break (CR, LF or CR+LF). The sensor enumeration of all devices starts at 1.

-for CAN bus version only-		
CAN_ID x	Set CAN-ID	#OK
CAN_IT x	Set interface x = 0: normal (11 bit, CAN 2.0A) x = 1 extended 23 bit (23 bit, CAN 2.0B)	#OK
CAN?	Request CAN configuration	#ID:0x[...]_Speed:[baud]_IDT:[0,1]
CAN_Speed x	Set CAN bus rate 0: 125 kBaud 1: 250 kBaud 2: 500 kBaud 3: 1 MBaud	#OK

Technical Drawing

Dimensions for a PSC24 device can be taken from the following drawing.

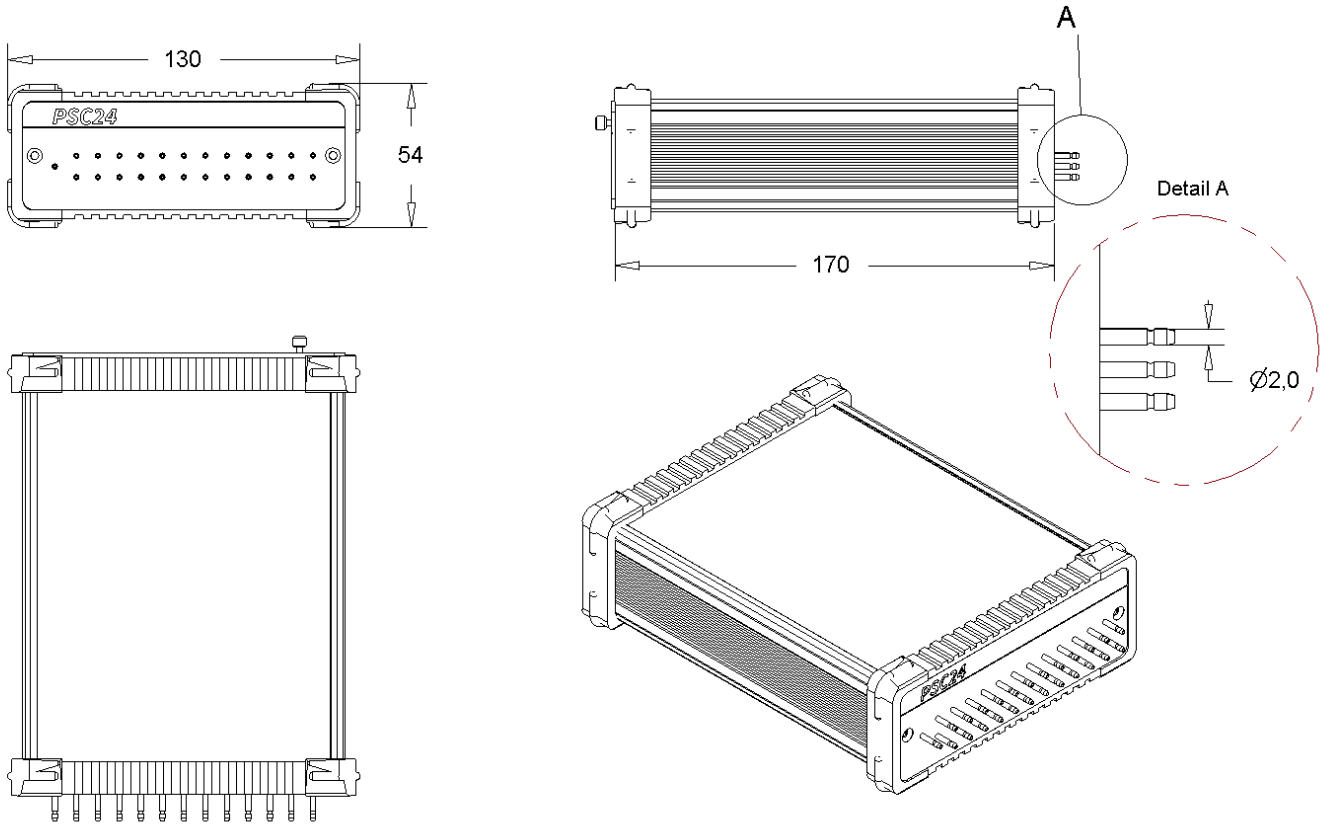

Figure: technical drawing and dimensions for a PSC24 pressure scanner.