

4CTA

Data Acquisition and Hot-Wire Measurement System

- High-dynamic measurements of flow velocities
- Velocity range: 0.1 – 50 m/s in air, higher velocities and other gases possible
- Measurement accuracy: 0.1 m/s + 0.5% FS ($v < 20$ m/s) / 1% FS ($20 < v < 50$ m/s)
- Data transfer via USB
- Software included
- Free analogue and digital in- and outputs onto customer-specific connectors
- Acoustic analysis via headphone



General Description

The 4CTA measurement system is a 4-channel hot-wire anemometer for simultaneous operation of up to 4 hot-wire probes. The hot-wire bridges are used for dynamic measurements of flow velocities in air (eCTA) and for the fast measurement of flow temperatures (eCCT). The calibrated velocity range in air reaches up to 50 m/s.

Due to the measurement principle the hot-wire anemometer is especially qualified for small flow velocities and transient or more specifically dynamic processes.

The system is ready to use on delivery as the included probes are already adjusted and calibrated. The signals of the hot-wire probes are directly gathered by the intern USB-data acquisition and are converted into velocities or temperatures.

By decoupling the fluctuations towards headphones, an intuitive sensation of the flow condition can be gained. As the ear is a good frequency analyser this is one of the most effective methods for the investigation of aero-acoustic problems.

In addition, a barometrical pressure sensor and a PT100 signal transducer are incorporated. The free analogues and digital in- and outputs of the data acquisition card can be connected onto customer-specific connectors to enable the connection of further sensors.

Composition of Hot-Wire Measurement System

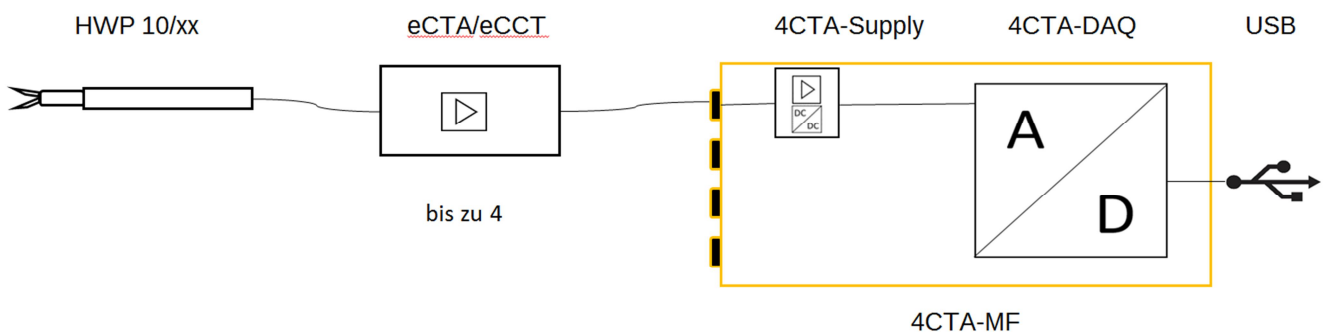

The measurement chain consists of four components:

Hot-wire probe – Hot-wire bridge – Supply and signal conditioning unit – A/D-converter.

Probe and bridge form a unit which must be calibrated as such. It must be considered that probe and bridge are in tune with each other and hence an elongation of the sensor cable is not possible. The connection cable of the eCTA-bridge can be customized.

Technical Specifications

Hot-wire measurement system	
Velocity range	0.1 - 50 m/s in air (calibrated) higher velocities possible, depending on temperature
Frequency resolution	0...5 kHz with 3dB lowpass, unfiltered up to 10 kHz is optional
Ambient conditions for hot-wire probes	
Fluid	Air, different non-corrosive gases are possible but must be calibrated separately, no particles, no air pollution
Temperature	10... 50°C within factory calibration, -10...60°C possible
Humidity	Non-condensing
Data acquisition card (option 4CTA-DAQ)	
National Instruments USB-6211 (different data acquisition card optional on request)	
Analogue inputs	16 channels, 16bit, 250kHz total sampling rate
Analogue outputs	2 channels, 16bit
Digital in- and outputs	4+4 channels, including 1 counter
Further intern components	
PT100 amplifier	0...300°C default, configurable
Barometric pressure sensor	800... 1100 hPa
CTA-Mainboard	Supply and signal conditioning eCTA/eCCT, per hot-wire probe
Power supply	
AC	110...264 V, 47-63 Hz, 100 W
DC	11... 18 V, min 4 A, 40 W (Binder 712 2 pin)

Configuration of signal inputs and signal outputs – connections front side	
PT100 temperature sensor, 1x	Binder 712, 2 pin
Hot-wire probe, up to 4	Binder 712, 7 pin
Audio volume and channel selection switch	
Earphones	3.5 mm audio jack
Analogue inputs, up to 10	BNC or customized
Analogue outputs, up to 2	BNC or customized
Digital in- and outputs	D-Sub 9 pin or customized
Ambient conditions for electronics	
Temperature	5...40°C
Humidity	Non-condensing
Dimensions	
case (H x B x T)	134 mm x 234 mm x 333 mm (19" 3HE 42TE)

Ordering Options

4CTA-MF	4CTA basic device
4CTA-DAQ	Data acquisition card
4CTA-Supply	Supply and amplifier for eCTA/eCCT necessary for each hot-wire probe
eCCT	Hot-wire bridge for temperature measurement
eCTA	Hot-wire bridge for velocity measurement
HWP10/xx	Hot-wire probes